

Double rating & high performance

SF-020-7.5K/5.5K-G~55K/45K-G
SF-040-7.5K/5.5K-G~355K/315K-G

Thank you for choosing Shihlin SF-G Series AC Drive.
The instruction will describe on the use and points for attention of products. Before installing, please be sure to carefully read the Installation Instructions, so that the inverter can be used in proper and safe way.

1) Safety Instructions

Safety Instructions

- Installation, operation, maintenance and inspection must be performed by qualified personnel.
- In this instruction, the safety instruction levels are classified into "Warning" and "Caution".
 - Warning: Incorrect handling may cause hazardous conditions, resulting in death or severe injury.
 - Caution: Incorrect handling may cause hazardous conditions, resulting in medium or slight injury, or may cause only material damage.

Warning

- While the inverter power is ON, do not open the front cover or the wiring cover. Do not run the inverter with the front cover or the wiring cover removed. Otherwise you may access the exposed high voltage terminals or the charging part of the circuitry and get an electric shock.
- It is crucial to turn off the motor drive power before any wiring installation or inspection is made. Before the inverter CHARGE light is OFF, which indicates that there is still high voltage in it, please do not touch the internal circuit and components. Operation must be made after measuring the voltage which is less than 24 VDC between +/P and -/N and with avometer.
- The inverter must be connected to the ground properly.
- Do not operate or touch the radiator or handle the cables with wet hands. Otherwise you may get an electric shock.
- Do not change the cooling fan while power is ON. It is dangerous to change the cooling fan while power is ON.

Caution

- The voltage applied to each terminal must be the ones specified in the Instruction Manual. Otherwise burst, damage, etc. may occur.
- Do not conduct a pressure test on the components inside the inverter, for semiconductor of the inverter is easily to be broke down and damaged by high voltage.
- While power is ON or for some time after power is OFF, do not touch the inverter as it will be extremely hot. Touching these devices may cause a burn.
- The cables must be connected to the correct terminals. Otherwise burst, damage, etc. may occur.
- The polarity (+ and -) must be correct. Otherwise burst, damage, etc. may occur.
- Inverter must be installed on a nonflammable wall without holes (so that nobody touches the inverter heat sink on the rear side, etc.). Mounting it to or near flammable material may cause a fire.
- If the inverter has become faulty, the inverter power must be switched OFF. A continuous flow of large current may cause a fire.
- Do not connect a resistor directly to the DC terminals +/P and -/N. Doing so could cause a fire.

2) Description of Product Model Number

SF - 040 - 7.5K/5.5K-G - **

Series category	Voltage level	Capacity	Others
SF series	-040 : 400V three-phase -020 : 200V three-phase	7.5KW/5.5KW	None : General model -** : Customer motor or dedicated motor or region difference

3) Installation Environment

Ambient temperature	-10 ~ +40°C (non-freezing).
Ambient humidity	Below 90%Rh (non-condensing).
Storage temperature	-20 ~ +65°C.
Surrounding environment	Indoor, no corrosive gas, no flammable gas, no flammable powder.
Altitude	Altitude below 1000 meters
Vibration	Below 5.9m/s ² (0.6G).
Grade of protection	IP20
The degree of pollution	2

4) Installation and Wiring

Please ensure vertical arrangement to keep the cooling effect:

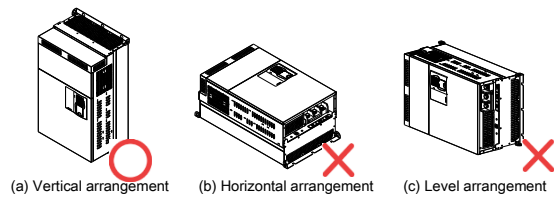

Please comply with installation conditions shown below to ensure enough ventilation space and wiring space for inverter cooling

Arrangement of single or paralleling inverter:

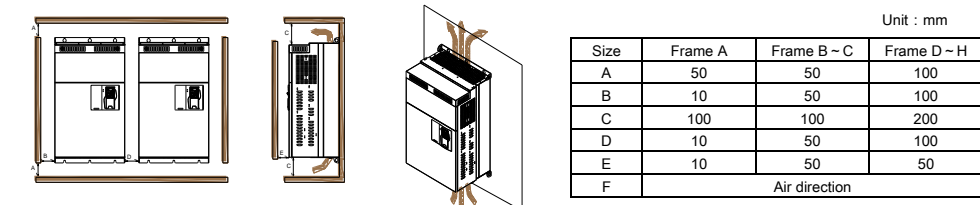

Arrangement of multiple inverters:

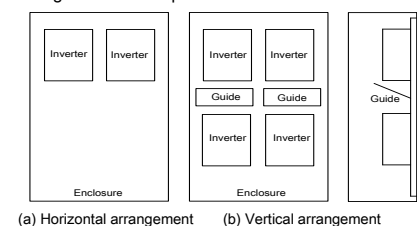

Note1: When mounting inverters of different sizes in parallel, please align the clearance above each inverter to install, which is easy to change the cooling fan.

Note2: When it is inevitable to arrange inverters vertically to small space, since heat from the bottom inverters can increase the temperatures in the top inverters, causing inverter failures. take such measures as to provide guides.

5) Terminal Connection Diagrams

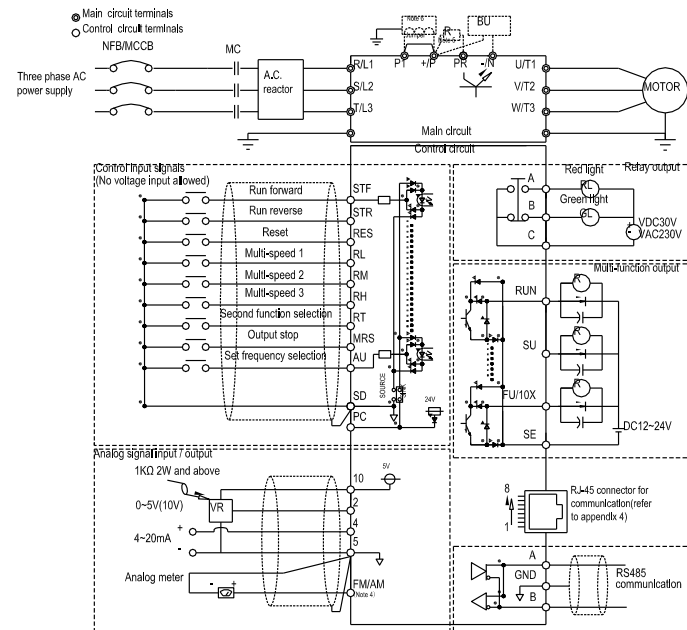

Note 1: Do not let the PC terminal and SD terminal with short circuit.

Note 2: Dc reactor can be selected between + /P and P1, if it is not used, can take directly short circuit.

Note 3: When FM/AM output terminals are selected for FM function, reference grounding is SD.

Note 4: Braking resistor connection method between +/P and PR is only used to the frame A and B. To the frame C, D, E, F, braking unit is between the (+/P) and (-N).

6) Main Circuit Wiring and Terminal Specification

Inverter model	Terminal screw specifications	Tightening torque (Kgf.cm)	Recommended wiring specification(mm ²)				Recommended wiring specification (AWG)					
			R, S, T	U, V, W	+ /P, P1	Grounding Cable	R, S, T	U, V, W	+ /P, P1	Grounding Cable		
SF-020-5.5K	M5	35	8	8	8	8	8	8	8	8		
SF-020-7.5K/5.5K-G			14	14	14	14	6	6	6	6		
SF-040-5.5K			6	6	6	6	10	10	10	10		
SF-040-7.5K/5.5K-G			6	6	6	6	10	10	10	10		
SF-040-11K/7.5K-G			8	8	8	8	8	8	8	8		
SF-040-15K/11K-G			14	14	14	14	6	6	6	6		
SF-020-11K/5.5K-G			25	25	25	16	4	4	4	4		
SF-020-15K/11K-G			35	35	35	16	2	2	2	4		
SF-020-18.5K/15K-G			50	50	50	25	1/0	1/0	1/0	2		
SF-020-22K/18.5K-G			60	60	60	30	2/0	2/0	2/0	2		
SF-020-30K/22K-G	M6	44	95	95	95	50	3/0	3/0	3/0	1/0		
SF-040-18.5K/15K-G			25	25	25	16	4	4	4	4		
SF-040-22K/18.5K-G			25	25	25	16	4	4	4	4		
SF-040-30K/22K-G			35	35	35	35	2	2	2	2		
SF-040-37K/30K-G			60	60	60	30	2/0	2/0	2/0	2		
SF-040-45K/37K-G			60	60	60	30	2/0	2/0	2/0	2		
SF-020-37K/30K-G			120	120	120	60	4/0	4/0	4/0	2/0		
SF-020-45K/37K-G			120	120	120	60	4/0	4/0	4/0	2/0		
SF-020-55K/45K-G			185	185	185	95	500	500	500	3/0		
SF-040-55K/45K-G			95	95	95	50	3/0	3/0	3/0	1/0		
SF-040-75K/55K-G	M8	61.2	120	120	120	60	4/0	4/0	4/0	2/0		
SF-040-90K/75K-G			120	120	120	60	4/0	4/0	4/0	2/0		
SF-040-110K/90K-G			185	185	185	95	500	500	500	3/0		
SF-040-132K/110K-G			95×2P	95×2P	95×2P	95	3/0×2P	3/0×2P	3/0×2P	3/0		
SF-040-160K/132K-G			240	240	240	120	4/0×2P	4/0×2P	4/0×2P	4/0		
SF-040-315K/280K-G			95×4P	95×4P	95×4P	95×2P	300×4P	300×4P	300×4P	300		
SF-040-350K/315K-G			95×4P	95×4P	95×4P	95×2P	300×4P	300×4P	300×4P	300		
SF-040-185K/160K-G			M10	102	120×2P	120×2P	120×2P	120	3/0×4P	3/0×4P	3/0×4P	4/0
SF-040-220K/185K-G					120×2P	120×2P	120×2P	120	3/0×4P	3/0×4P	3/0×4P	4/0
SF-040-250K/220K-G					150×2P	150×2P	150×2P	150	4/0×4P	/0×4P	/0×4P	4/0
SF-040-280K/250K-G	120×2P	150×2P			150×2P	150	4/0×4P	/0×4P	/0×4P	4/0		

Arrangement of main circuit terminal

1. Frame A

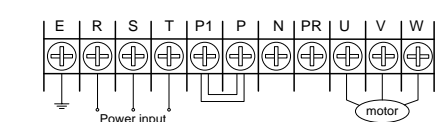

2. Frame B

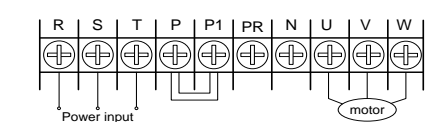

3. Frame C

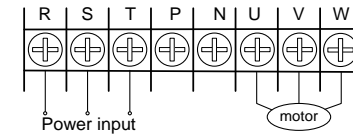

4. Frame D/E/F

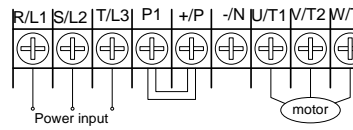

5. Frame G

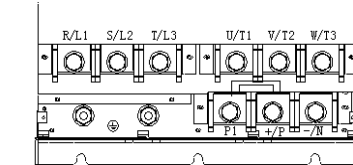

6. Frame H

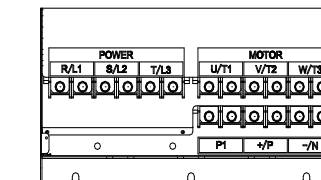

7) Control Terminal

Arrangement of control terminal

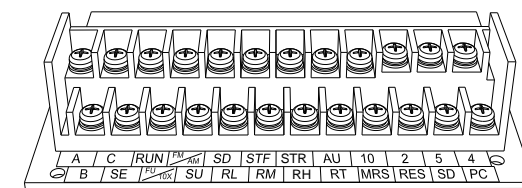

Control terminal description

Terminal type	Terminal name	Function instructions	Terminal specifications
Switch signal input	STF	There are totally 10 multi-function control terminals, which can switch mode of SINK/SOURCE.	Input impedance: 4.7 kΩ Action current: 5mA(when 24VDC) Voltage range: 10~28VDC Maximum frequency: 1kHz
	STR		
	RL		
	RM		
	RH		
	AU		
	RT		
	MRS		
	RES		
	SD		
Analog signal input	PC	In the mode of SOURCE, provide common power supply of these terminals above.	Output voltage : 24VDC±20% Maximum current : 5mA
	10	There is 5V power inside the terminals.	Maximum current:10mA
Relay output	2	Voltage is 0~5v or 0~10v input point, to set the target frequency.	
	4	Current is 4~20mA input point, to set the target frequency.	
	5	Common reference of 10, 2, 4, and AM terminal	---
Open collector output	A	Multi-function relay output terminals. A-C is the normally open contact, B-C is the normally closed contact, C is common terminal.	Maximum voltage: 48VDC Maximum current:50mA
	B		
	C		
Analog /Pulse signal output	SU	Multi-function open collector output terminal	Maximum voltage: 48VDC Maximum current:50mA
	RUN		
	FU/10X		
Communication terminal	SE	The reference of open collector output	---
	A/GND/B	Connector of inverter and RS-485 communication interface	Highest rate:19200bps Longest distance:500m

Note1 : When connecting control terminal with external devices, please pay attention to the voltage and current specifications of terminals, avoiding damaging the inverter.

Note2 : The function of the control terminal is decided by inverter parameters; please refer to Instruction Manual for setting.

Note3 : Please pay attention to polarity when connecting external power and devices.

➤ Wiring method

Control terminal screw: M3

Tightening torque : 8kgf.cm

- Power supply connection

Recommended connecting the wire using insulation covering U terminal

U terminal is applied to the wire, which cross-sectional area is 0.3 ~ 0.75 mm², suggesting that d1 is 3.2 mm, d2 is 6.2mm or less.

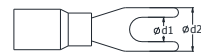

Note 1: Please Use a small cross head screw driver.

Note 2: Tightening torque is 8kgf.cm, too large tightening torque can cause crew slippage; too little tightening torque can cause a short circuit or malfunction

➤ Wiring Precautions

- After wiring, wire offcuts must not be left in the inverter.

Wire offcuts can cause an alarm, failure or malfunction. Always keep the inverter clean.

When drilling mounting holes in an enclosure etc., please take caution not to allow chips powder to enter the inverter.

- To prevent a malfunction due to noise, keep the signal cables 10cm (3.94 inches) or more away from the power cables.

Also, separate the main circuit cables at the input side from the main circuit cables at the output side.

- Set the voltage/current input switch correctly. Incorrect setting may cause a fault, failure or malfunction.

8) Appearance and Dimensions

➤ Frame A/B

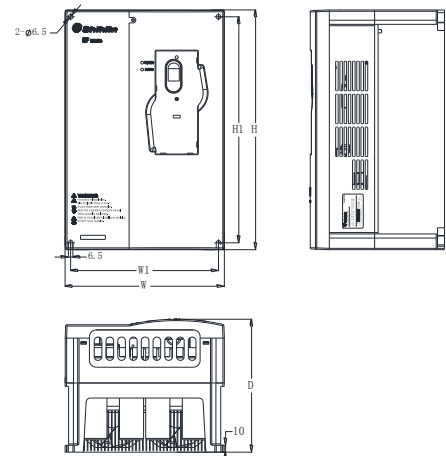

Model	Frame	W	W1	H	H1	D
SF-040-5.5K	A	200	186	323	303	186
SF-040-7.5K/5.5K-G						
SF-020-5.5K						
SF-020-7.5K/5.5K-G						
SF-040-11K/7.5K-G						
SF-040-15K/11K-G	B	230	214	350	330	195
SF-020-11K/7.5K-G						
SF-020-15K/11K-G						
SF-020-18.5K/15K-G						
SF-040-18.5K/15K-G						
SF-040-22K/18.5K-G						

➤ Frame C

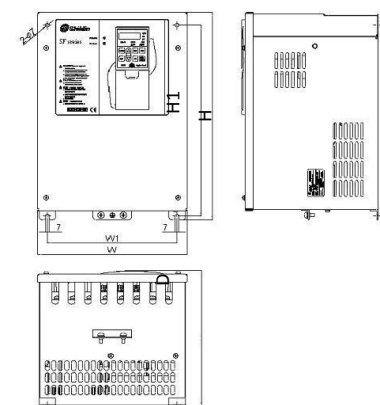

Model	Frame	W	W1	H	H1	D
SF-020-22K/18.5K-G	C	271	236	379	348	248

➤ Frame D/E/F

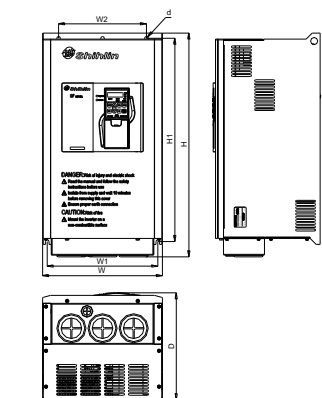

Model	Frame	W	W1	W2	H	H1	D	d
SF-040-30K/22K-G	D	300	277	220	561	510	270	9
SF-040-37K/30K-G								
SF-040-45K/37K-G								
SF-040-55K/45K-G	E	370	336	336	595	566	286	13
SF-020-37K/30K-G								
SF-040-75K/55K-G								
SF-040-90K/75K-G	F	425	381	381	850	821	286	13
SF-020-45K/37K-G								
SF-020-55K/45K-G								
SF-040-110K/90K-G								
SF-040-132K/110K-G								
SF-040-160K/132K-G								

➤ Frame G/H

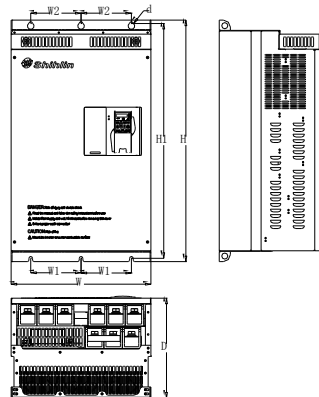

Model	Frame	W	W1	W2	H	H1	D	d
SF-040-185K/160K-G	G	500	180	180	870	850	360	13
SF-040-220K/185K-G								
SF-040-250K/220K-G								
SF-040-280K/250K-G	H	600	230	230	1000	980	400	13
SF-040-315K/280K-G								
SF-040-355K/315K-G								

➤ Flange installation schematic diagram of frame G, H, as follows:

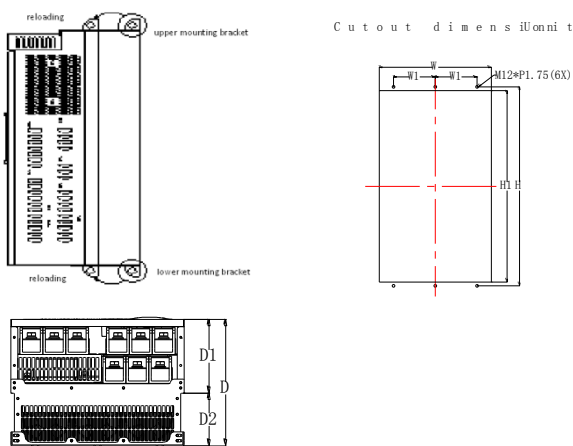

Model	Frame	H	H1	W	W1	D	D1	D2
SF-040-185K/160K-G	G	850	817	486	180	360	210	150
SF-040-220K/185K-G								
SF-040-250K/220K-G								
SF-040-280K/250K-G	H	980	931	590	230	400	218.5	181.5
SF-040-315K/280K-G								
SF-040-355K/315K-G								

9) Optional Equipment

Sort	Type	Description	Order code
manipulator	DU01S	LED manipulator	SNKDU301S
	PU01	LED manipulator	SNKSHPU01
Expansion card	PM01	PM01 injection molding machine Special expansion card	SNSFGPM01
	WS01	Fan pump multiplex control card	SNKSFWS01
	PG01	PG01 expansion card	SNKPG01
Other optional equipment	CBL1R5GT	The data transmission line (1.5 m)	SNKCBL1R5GT
	CBL03GT	The data transmission line (3 m)	SNKCBL03GT
	CBL05GT	The data transmission line (5 m)	SNKCBL05GT

10) Parameter Table

Parameter number	Name	Setting range	Default value	User setting value
P.0	Torque boost	0~30%	Model-based(Not e 1)	
P.1	Maximum frequency	0~120Hz	120Hz(55kW or below) 60Hz(75kW or above)	
P.2	Minimum frequency	0~120Hz	0Hz	
P.3	Base frequency	0~400Hz	50Hz/60Hz (Note 2)	
P.4	Speed 1 (high speed)	0~400Hz	60Hz	
P.5	Speed 2 (medium speed)	0~400Hz	30Hz	
P.6	Speed 3 (low speed)	0~400Hz	10Hz	
P.7	Acceleration time	0~360s/0~3600s	20s	
P.8	Deceleration time	0~360s/0~3600s	10s(7.5kW or below) 30s(11kW or above)	
P.9	Electronic thermal relay capacity	0~500A/5000A (Note 5)	Motor rated current (Note 1)	
P.10	DC injection brake operation frequency	0~120Hz	3Hz	
P.11	DC injection brake operation time	0~60s	0.5s	
P.12	DC injection brake operation voltage	0~30%	4%(7.5kW or below) 2%(11kW~55kW) 1%(75kW or above)	
P.13	Starting frequency	0~60Hz	0.5Hz	
P.14	Load pattern selection	0: Applicable to constant torque loads(convey belt, etc.) 1: Applicable to variable torque loads (fans and pumps, etc.) 2, 3: Applicable to ascending / descending loads. 4: Multipoint VF curve. 5 ~ 13: Special two-point VF curve.	0	
P.15	JOG frequency	0~400Hz	5Hz	
P.16	JOG acceleration /deceleration time	0~360s/0~3600s	0.5s	
P.17	Reserve	---	---	
P.18	High speed maximum frequency	120~400Hz	120Hz	
P.19	Base frequency voltage	0~1000V, 99999	99999	
P.20	Acceleration / deceleration reference frequency	1~400Hz	50Hz/60Hz (Note 2)	
P.21	Acceleration/deceleration time increments	0: Time increment is 0.01s 1: Time increment is 0.1s	0	

Parameter number	Name	Setting range	Default value	User setting value
P.22	Stall prevention operation level	0~400%	120%/150%	
P.23	Compensation factor at level reduction	0~150%, 99999	99999	
P.24	Speed 4	0~400Hz, 99999	99999	
P.25	Speed 5	0~400Hz, 99999	99999	
P.26	Speed 6	0~400Hz, 99999	99999	
P.27	Speed 7	0~400Hz, 99999	99999	
P.28	Output frequency filter constant	0~31	0	
P.29	Acceleration/ deceleration curve selection	0: linear acceleration /deceleration curve 1: S pattern acceleration /deceleration curve 1 2: S pattern acceleration /deceleration curve 2	0	
P.30	Regenerative brake function selection	0: If regenerative brake duty is fixed at 3%, parameter P.70 will be invalid. 1: The regenerative brake duty is the set value of P.70 2: External brake unit protection function	0/2	
P.31	Carrier operation selection	0: The rated current decreases with rated carrier change 1: when P.72 < 5, Soft-PWM is valid (only apply to V/F control) 2: When P.72 > 9(note 2), the temperature of module is higher than 60 degree, carrier will decrease to 9k automatically (note 2); after the temperature drops to lower than 40 degree, carrier will restore the setting value of P.72 automatically	0	
P.32	Serial communication Baud rate selection	0: Baud rate:4800bps 1: Baud rate:9600bps 2: Baud rate:19200bps	1	
P.33	Communication protocol selection	0: Modbus protocol 1: Shihlin protocol	1	
P.34	Block communication EEPROM write options	0 : Through communication in parameter, block write EEPROM, RAM 1 : Through communication in parameter, block write RAM	0	
P.35	Communication mode operation & speed command selection	0: both operation command and speed command are given by communication 1: both operation command and speed command are given by the external	0	
P.36	Inverter station number	0~254	0	
P.37	Speed display	0~5000r/min, 0~9999 r/min	0 r/min	
P.38	The maximum operation frequency (the target frequency is set by the input signal of terminal 2-5)	1~400Hz	50Hz/60Hz (Note 2)	
P.39	The maximum operation frequency (the target frequency is set by the input signal of terminal 4-5)	1~400Hz	50Hz/60Hz (Note 2)	
P.40	Multi-function output terminal SU function selection	0: RUN (Inverter running): Signals will be sent out when output frequency is equal to or higher than the starting frequency. 1: SU (Reaching the output frequency): Signals will be sent out once the output frequency reaches the set frequency. 2: FU (Output frequency detection): It is the output signal when detecting the frequency exceeding the assigned frequency during the operation. 3: OL (Overload detection): It is the output signal when the current limit function is triggered. (When P.260=1 and OL2 alarm is output, OL is output) 4: OMD (Zero current detection): If the current output percentage of the inverter is less than the set value of P.62 and has exceeded P.63 for a period of time, OMD will output the signal. 5: ALARM (Alarm detection): An alarm signal detected. 6: PO1 (Section detection): In the programmed operation mode, the signal will be sent out at the end of each frequency operation. 7: PO2 (Periodical detection): In the programmed operation mode, the signal will be sent out at the end of each operation cycle. 8: PO3 (Pause detection): In the programmed operation mode, the signal will be sent out when the operation is suspended. 9: BP (Inverter output): Switch between the inverter operation and the commercial power-supply operation; in inverter operation, BP will send out signals. 10: GP (Commercial power-supply output): Switch between the inverter operation and the commercial power-supply operation function; in the commercial power-supply operation, GP will send out signals. 11: AUX (Aux output): If multimachine constant pressure system function selected, when the second water pump is operating, AUX will output signal. 12~15: Please refer to the manual for the fan's water pump multiple cards. 16: Abnormal signal of fan 17: RY (the inverter running preparation accomplishment): After the inverter is powered on, the signal is output when the reset operation is completed (the starting signal ON is in the started state) 18: Maintenance Alarm detection 19: OL2(Over torque alarm output): please refer to P.260	1	
P.41	Up-to-frequency sensitivity	0~100%	10%	
P.42	Output frequency detection for forward rotation	0~400Hz	6Hz	
P.43	Output frequency detection for reverse rotation	0~400Hz, 99999	99999	
P.44	The second acceleration time	0~360s/0~3600s, 99999	99999	
P.45	The second deceleration time	0~360s/0~3600s, 99999	99999	
P.46	The second torque boost	0~30%, 99999	99999	
P.47	The second base frequency	0~400Hz, 99999	99999	
P.48	Data length	0: 8bit 1: 7bit	0	
P.49	Stop bit length	0: 1bit 1: 2bit	0	
P.50	Parity check selection	0: No parity verification 1: Odd 2: Even	0	
P.51	CR & LF selection	1: CR only 2: Both CR and LF	1	
P.52	Number of communication abnormal condition	0~10	1	

Parameter number	Name	Setting range	Default value	User setting value
P.53	Communication check time interval	0-999.8s, 99999	99999	
P.54	FM/AM terminal function selection	0-5	0	
P.55	Frequency display reference	0-400Hz	50Hz/60Hz (Note 2)	
P.56	Current monitoring reference	0-500A/5000A (Note 5)	Rated output current	
P.57	Restart coasting time	0-30s, 99999	99999	
P.58	Restart cushion time	0-60s	5s (7.5kW 以下) 10s (11kW-55kW) 20s (75kW 以上)	
P.59	Reserve	---	---	
P.60	Input signal filter constant}	0-2047	31	
P.61	Remote setting function selection	0: No remote setting function. 1: Remote setting function, frequency setup storage is available. 2: Remote setting function, frequency setup storage is not available. 3: Remote setting function, frequency setup storage is not available, the remote setting frequency is cleared by STF/STR "turn off".	0	
P.62	Zero current detection level	0-200%, 99999	5%	
P.63	Zero current detection time	0.05-1s, 99999	0.5s	
P.64	FM/AM output terminal selection	0, 1	0	
P.65	Retry selection	0: Retry is invalid. 1: Over-voltage occurs, the AC Drive will perform the retry function. 2: Over-current occurs, the AC Drive will perform the retry function. 3: Over-voltage or over-current occurs, the AC Drive will perform the retry function. 4: All the alarms have the retry function.	0	
P.66	Stall prevention operation reduction starting frequency	0-400Hz	50Hz/60Hz (Note 2)	
P.67	Number of retries at alarm occurrence	0-10	0	
P.68	Retry waiting time	0-360s	1s	
P.69	Retry accumulation time at alarm	0	0	
P.70	Special regenerative brake duty	0-60%	0	
P.71	Idling braking and linear braking selection	0: Idling braking 1: DC braking	1	
P.72	Carrier frequency	Frame A/B/C: 0.7-14.5KHZ Frame D/E: 0.7-9KHZ Frame F/G: 0.7-9KHZ Frame H: 0.7-6KHZ	Frame A/B/C: 5KHZ Frame D/E: 4KHZ Frame F/G: 2KHZ Frame H: 2KHZ	
P.73	Voltage signal selection	0: The valid range of signal sampling (terminal 2-5) is 0-5V 1: The valid range of voltage signal sampling (terminal 2-5) is 0-10V	0	
P.74	FU/10X output terminal selection	0-10	0	
P.75	Stop or reset function selection	0: Press STOP button and stop the operation only in PU and H2 mode 1: Press STOP button and stop the operation in all mode.	1	
P.76	Reserve	---	---	
P.77	Parameters write protection	0: Parameters can be written only when the motor stops. 1: Parameters cannot be written. 2: Parameters can also be written when the motor is running. 4: Parameters cannot be written when in password protection.	0	
P.78	Forward/reverse rotation prevention selection	0: Forward rotation and reverse rotation are both permitted. 1: Reverse rotation is prohibited (Press the reverse reference to decelerate and stop the motor). 2: Forward rotation is prohibited (Press the forward rotation reference to decelerate and stop the motor).	0	
P.79	Operation mode selection	0: "PU mode", "external mode" and "Jog mode" are interchangeable. 1: "PU mode" and "JOG mode" are interchangeable. 2: "External mode" only 3: "Communication mode" only 4: "Combined mode 1" 5: "Combined mode 2" 6: "Combined mode 3" 7: "Combined mode 4" 8: "Combined mode 5"	0	
P.80	Multi-function terminal RL function selection	0: STF 1: STR 2: RL (Multi-speed) 3: RM (Multi-speed) 4: RH (Multi-speed) 5: AU 6: OH 7: MRS 8: RT 9: EXJ (External JOG) 10: STF+EXJ 11: STR+EXJ 12: STF+RT 13: STR+RT 14: STF+RL 15: STR+RL 16: STF+RM 17: STR+RM 18: STF+RH 19: STR+RH 20: STF+RL+RM 21: STR+RL+RM 22: STF+RT+RL 23: STR+RT+RL 24: STF+RT+RM 25: STR+RT+RM 26: STF+RT+RL+RM 27: STR+RT+RL+RM 28: RUN 29: STF/STR 30: RES (External reset function) 31: STOP 32: REX (Multi-speed set (16 levels)) 33: PO (In "external mode" and when PO is "on", programmed operation mode is chosen) 34: RES_E (When alarms occur, external reset become valid only when the alarm goes off.) 35: MPO (In "external mode" and when MPO is "on", the manually operation cycle mode is chosen.)	2	

Parameter number	Name	Setting range	Default value	User setting value
P.80	Multi-function terminal RL function selection	36: TRI (Triangle wave function) 37: GP BP 38: CS (Manual switch power frequency signal) 39 : STF/STR +STOP 40-43 : reserve 44 : PID_OFF 45 : SEC FRE	2	
P.81	Multi-function terminal RM function selection	Same as P.80	3	
P.82	Multi-function terminal RH function selection	Same as P.80	4	
P.83	Multi-function terminal STF function selection	Same as P.80	0	
P.84	Multi-function terminal STR function selection	Same as P.80	1	
P.85	Function selection for multi-function relay	Same as P.40	5	
P.86	Multi-function terminal RES function selection	Same as P.80	30	
P.87	Multi-Function Control-Terminal Input Positive/Negative Logic	0-511	0	
P.88	Multi-Function Output-Terminal Positive/Negative Logic	0-15	0	
P.89	Slip compensation coefficient	0-10	0	
P.90	Inverter model Inverter model	0-4000	0	
P.91	Frequency jump 1A	0-400Hz, 99999	99999	
P.92	Frequency jump 1B	0-400Hz, 99999	99999	
P.93	Frequency jump 2A	0-400Hz, 99999	99999	
P.94	Frequency jump 2B	0-400Hz, 99999	99999	
P.95	Frequency jump 3A	0-400Hz, 99999	99999	
P.96	Frequency jump 3B	0-400Hz, 99999	99999	
P.97	The second target frequency selection	0-2	0	
P.98	Middle frequency 1	0-400Hz	3Hz	
P.99	Output voltage 1 of middle frequency	0-100%	10%	
P.100	Minute/second selection	0: The minimum increment of run time is 1 minute. 1: The minimum increment of run time is 1 second.	1	
P.101	Runtime of Section 1 in programmed operation mode	0-6000s	0s	
P.102	Runtime of Section 2 in programmed operation mode	0-6000s	0s	
P.103	Runtime of Section 3 in programmed operation mode	0-6000s	0s	
P.104	Runtime of Section 4 in programmed operation mode	0-6000s	0s	
P.105	Runtime of section 5 in programmed operation mode	0-6000s	0s	
P.106	Runtime of section 6 in programmed operation mode	0-6000s	0s	
P.107	Runtime of Section 7 in programmed operation mode	0-6000s	0s	
P.108	Runtime of Section 8 in programmed operation mode	0-6000s	0s	
P.110	Operation panel monitoring selection	0 : When the inverter starts, the operation panel enters the monitoring mode automatically, and the screen displays the output frequency. 1 : When the inverter starts, the screen of the operation panel displays the target frequency. 2 : When the inverter starts, the operation panel enters the monitoring mode automatically, and the screen displays the current pressure and feedback pressure of the constant pressure system	1	
P.111	Acceleration/deceleration time of section 1	0-600s/0-6000s	0s	
P.112	Acceleration/deceleration time of section 2	0-600s/0-6000s	0s	
P.113	Acceleration/deceleration time of Section 3	0-600s/0-6000s	0s	
P.114	Acceleration/deceleration time of Section 4	0-600s/0-6000s	0s	
P.115	Acceleration/deceleration time of Section 5	0-600s/0-6000s	0s	
P.116	Acceleration/deceleration time of Section 6	0-600s/0-6000s	0s	
P.117	Acceleration/deceleration time of Section 7	0-600s/0-6000s	0s	
P.118	Acceleration/deceleration time of Section 8	0-600s/0-6000s	0s	
P.119	The dead time of forward/reverse	0-3000s	0s	
P.120	Output signal delay time	0-3600s	0s	
P.121	Run direction in each section	0-255	0	
P.122	Cycle selection	0-8	0	
P.123	Acceleration/deceleration time setting selection	0, 1	0	
P.125	Reserve	---	---	
P.126	Multi-function terminal AU function selection	Same as P.80	5	
P.127	Multi-function terminal RT function selection	Same as P.80	8	
P.128	Multi-function terminal MRS function selection	Same as P.80	7	
P.129	Multi-function terminal RUN function selection	Same as P.40	0	
P.130	Multi-function terminal FU/10X function selection	Same as P.40	2	
P.131	Frequency of section 1	0-400Hz	0Hz	
P.132	Frequency of section 2	0-400Hz	0Hz	
P.133	Frequency of section 3	0-400Hz	0Hz	
P.134	Frequency of section 4	0-400Hz	0Hz	
P.135	Frequency of section 5	0-400Hz	0Hz	
P.136	Frequency of section 6	0-400Hz	0Hz	
P.137	Frequency of section 7	0-400Hz	0Hz	
P.138	Frequency of section 8	0-400Hz	0Hz	
P.139	Voltage signal bias	0-100%	0%	
P.140	Voltage signal gain	0.1-200%	100%	
P.141	Voltage signal bias direction and rotational direction setup	0-11	0	
P.142	Speed 8	0-400Hz	0Hz	
P.143	Speed 9	0-400Hz, 99999	99999	
P.144	Speed 10	0-400Hz, 99999	99999	
P.145	Speed 11	0-400Hz, 99999	99999	
P.146	Speed 12	0-400Hz, 99999	99999	
P.147	Speed 13	0-400Hz, 99999	99999	
P.148	Speed 14	0-400Hz, 99999	99999	
P.149	Speed 15	0-400Hz, 99999	99999	
P.150	Restart mode selection	XXX0 : No frequency search XXX1 : Immediate frequency search XXX2: Cheaper voltage	0	

Parameter number	Name	Setting range	Default value	User setting value
P.150	Restart mode selection	XX0X: One electrify XX1X: Every starting XX2X: Stop momentary X0XX: No detection of rotation X1XX: The detection of rotation X2XX: P78=0, The direction of rotation; P78=1, 2 No direction of rotation	0	
P.151	Zero-speed control function selection	0 : There is no output at zero-speed. 1 : Control by DC (Note 1 and 3)	0	
P.152	Voltage instruction at zero-speed control	0-30%	4% (7.5kW or below) 2% (11kW-55kW) 1% (75kW or above)	
P.153	Communication error handling	0: Warn and call to stop 1: Don't alarm and continue running	0	
P.154	Modbus communication data format	0: 1, 7, N, 2 (Modbus, ASCII) 1: 1, 7, E, 1 (Modbus, ASCII) 2: 1, 7, O, 1 (Modbus, ASCII) 3: 1, 8, N, 2 (Modbus, RTU) 4: 1, 8, E, 1 (Modbus, RTU) 5: 1, 8, O, 1 (Modbus, RTU)	4	
P.155	Over-torque detection level	0-200%	0%	
P.156	Over-torque detection time	0.1-60s	1s	
P.157	External terminals filter adjusting function	0-200	4	
P.158	External terminal power enable	0: Digital input terminal power enable 1: Digital input terminal power enable	0	
P.159	Energy-saving control function	0: Normal running mode. 1: Energy-saving running mode.	0	
P.160	Stall prevention operation level when restart	0-150%	100%	
P.161	Multi-function display selection	0 : The monitoring voltage file displays the current voltage 1: The monitoring voltage file displays the current voltage between P and N terminals 2: The monitoring voltage file displays the accumulation rate of temperature increase of the inverter. 3: The monitoring voltage file displays the current target pressure of the constant pressure system 4: The monitoring voltage file displays the current feedback pressure of the constant pressure system 5: The monitoring voltage file displays the current operation frequency 6: The monitoring voltage file displays the current electronic thermal accumulation rate 7: The monitoring voltage file displays the signal value (V) of 2-5 simulating input terminals 8: The monitoring voltage file displays the signal value (mA) of 4-5 simulating input terminals 9: The monitoring voltage file displays the output power (kW) 10: The monitoring voltage file displays PG card's feedback rotation speed 11: The monitoring voltage file displays forward and reverse rotation signal. Then 1 represents forward rotation, 2 represents reverse rotation, and 0 represents stopping state 12: The monitoring voltage file displays module temperature 13: The monitoring voltage file displays the electronic thermal accumulation rate of motor 14-17: Reserved 18: The monitoring voltage file displays output torque of inverter (%) 19: External terminal input state (about the sort of terminal, please refer to the table of the special monitor code in the communication part) 20: External terminal output state (about the sort of terminal, please refer to the table of the special monitor code in the communication part) 21: Show the current effective carrier 22-23: Reserved 24: Show the current target frequency	0	
P.162	Middle frequency 2	0-400Hz, 99999	99999	
P.163	Output voltage 2 of middle frequency	0-100%	0	
P.164	Middle frequency 3	0-400Hz, 99999	99999	
P.165	Output voltage 3 of middle frequency	0-100%	0	
P.166	Middle frequency 4	0-400Hz, 99999	99999	
P.167	Output voltage 4 of middle frequency	0-100%	0	
P.168	Middle frequency 5	0-400Hz, 99999	99999	
P.169	Output voltage 5 of middle frequency	0-100%	0	
P.170	PID function selection	0: PID function non-selected 1: The target value is determined by P.225. The feedback value is determined by the voltage of terminal 2-5 2: The target value is determined by P.225. The feedback value is determined by the voltage of terminal 4-5	0	
P.171	PID feedback control method selection	0: Negative feedback control The calculation for the deviation is target value minus the feedback value. When an increase in the output frequency will increase the feedback value, select this setup 1: Positive feedback control The calculation for the deviation is feedback value minus the target value. When an increase in the output frequency will decrease the feedback value, select this setup	0	
P.172	PID proportion Gain	1-100	20	
P.173	PID integration Gain	0-100s	1s	
P.174	PID differential Gain	0-1000ms	0ms	
P.175	Abnormal deviation level	0-100%	0	
P.176	Exception duration time	0-600s	30s	
P.177	Exception handling mode	0: Free stop 1: Decelerate and stop 2: Continue to run when the alarm goes off	0	
P.178	Sleep detects deviation	0-100%	0	

Parameter number	Name	Setting range	Default value	User setting value
P.179	Sleep detects duration time	0~255s	1s	
P.180	Revival level	0~100%	90%	
P.181	Outage level	0~120Hz	40Hz	
P.182	Integral upper limit frequency	0~120Hz	50Hz/60Hz (Note 2)	
P.183	Deceleration step length with stable pressure	0~10Hz	0.5Hz	
P.184	terminal disconnection handling	0: No disconnection selection is available. 1: Decelerate to 0Hz, the digital output terminal will set off the alarm. 2: AC Drive will stop immediately, and the panel will display "AErr" alarm. 3: AC Drive will run continuously according to frequency reference before disconnection. The digital output terminal will set off alarm.	0	
P.186	SF-G model selection function	0, 1	0	
P.187	FM calibration parameter	0~9998	166	
P.188	Software firmware version	---	---	
P.189	Factory setting function	0: The default value of frequency-related parameter belongs to the 60Hz system. 1: The default value of frequency-related parameter belongs to the 50Hz system	0(60Hz System) 1(50Hz System)	
P.190	AM output bias	0~1400	0 (Note 4)	
P.191	AM output gain	0~1400	1335 (Note 4)	
P.192	2-5 terminal minimum input voltage	0~10	0	
P.193	2-5 terminal maximum input voltage	0~10	0	
P.194	Frequency corresponds to the minimum input voltage of terminal 2-5	0~60Hz	0Hz	
P.195	Frequency corresponds to the maximum input voltage of terminal 2-5	0~400Hz	50Hz/60Hz (Note 2)	
P.196	4-5 terminal minimum input current corresponded frequency	0~60Hz	0Hz	
P.197	4-5 terminal maximum input current corresponded frequency	0~400Hz	50Hz/60Hz(Note 2)	
P.198	4-5 terminal minimum input current	0~20	0	
P.199	4-5 terminal maximum input current	0~20	0	
P.200	Constant pressure system function selection	0~14	0	
P.209	Maximum frequency duration	0.1~10min	5min	
P.210	Minimum frequency duration	0.1~10min	5min	
P.213	Acceleration time for starting the commercial power supply frequency	0.01~20s/0.1~200s	5s	
P.214	Deceleration time for starting the commercial power supply frequency	0.01~20s/0.1~200s	5s	
P.215	Maximum frequency	20~60Hz	50Hz	
P.216	Minimum frequency	0~20Hz	20Hz	
P.217	Motor switchover permitted deviation	0~20%	0	
P.223	Analog feedback bias pressure	0~100%	0%	
P.224	Analog feedback gain pressure	0~100%	100%	
P.225	Panel command	0~100%,99999	20%	
P.229	Backlash compensation function selection	0~1	0	
P.230	The backlash compensation acceleration interrupt frequency	0~400Hz	1Hz	
P.231	The back lash compensation acceleration interrupt time	0~360 s	0.5s	
P.232	The back lash compensation deceleration interrupt frequency	0~400Hz	1Hz	
P.233	The backlash compensation deceleration interrupt time	0~360 s	0.5s	
P.234	Triangular wave function selection	0: None. 1: External TRI is turned on, triangular wave function will be valid. 2: The triangular wave function is effective at any given time.	0	
P.235	Maximum amplitude	0~25%	10%	
P.236	Amplitude compensation for deceleration	0~50%	10%	
P.237	Amplitude compensation for acceleration	0~50%	10%	
P.238	Amplitude acceleration time	0~360s/0~3600 s	10s	
P.239	Amplitude deceleration time	0~360s/0~3600s	10s	
P.240	Auxiliary frequency function selection	0: no auxiliary frequency function is available 1: operation frequency = basic frequency + auxiliary frequency (given by the 2-5 terminal) 2: operation frequency = basic frequency + auxiliary frequency (given by the 4-5 terminal) 3: operation frequency = basic frequency - auxiliary frequency (given by the 2-5 terminal) 4: operation frequency = basic frequency - auxiliary frequency (given by the 4-5 terminal)	0	
P.242	DC injection brake function before starting selection	0: DC injection brake function is not available before starting. 1: DC brake injection function is selected before starting.	0	
P.243	DC injection brake time before starting	0~60s	0.5s	
P.244	DC injection brake voltage before starting	0~30%	4% (7.5kW or below) 2% (11kW~55kW) 1% (75kW or above)	
P.245	Cooling fan operation selection	0~3, 10~13	0	
P.246	Modulation coefficient	0.90~1.20	1	
P.247	MC switchover interlock time	0.1~100s	1s	
P.248	Start waiting time	0.1~100s	0.5s	
P.249	Automatic switchover frequency from inverter to commercial power supply frequency	0~60Hz,99999	99999	
P.250	Automatic switchover frequency range from commercial power supply to inverter	0~10Hz,99999	99999	
P.251	Injection molding machine mode selection	0: no injection modeling machine function 1: only the flow channel is valid 2: only the pressure channel is valid 3: Flow channel and stress combination set frequency 4: Flow channel and pressure taking absolute value	0	
P.252	Flow channel weighted coefficient	0~100%	100%	
P.253	Pressure channel weighted coefficient	0~100%	100%	
P.254	Corner frequency	0~100Hz	0 Hz	
P.259	Speed unit selection	0~1	1	
P.260	Over torque detection selection	0: The OL2 alarm is not reported after the over torque detection, and AC Drive keeps running. 1: The OL2 alarm is reported after over torque detection, and AC Drive stops.	1	
P.261	Maintenance alarm time	0~9998 day	0	
P.281	Input phase failure protection	0: No Phase Failure Protection 1: Phase Failure Protection	0	

Parameter number	Name	Setting range	Default value	User setting value
P.285	Low frequency vibration inhibition factor	0~3	1	
P.286	High frequency vibration inhibition factor	0~15	0	
P.287	Short circuit protection (SCP) function selection	0~1	1	
P.288	Alarm code display option	0~12	0	
P.289	Alarm code	---	0	
P.290	The latest alarm status selection	0~7	0	
P.291	The latest alarm message	---	0	
P.292	Accumulative motor operation time (minutes)	0~1439 min	0 min	
P.293	Accumulative motor operation time (days)	0~9999 day	0 day	
P.294	Decryption parameter	0~65535	0	
P.295	Password setup	2~65535	0	
P.300	Motor control mode selection	0: V/F control 1: Close-loop V/F control (VF + PG) 2: General flux vector control 3: Sensorless vector control (SVC) 4: Close-loop vector control (FOC + PG)	0	
P.301	Motor parameter auto-tuning function selection	0: Parameter auto-tuning function with no motor 1: Motor parameter auto-tuning measuring the running motor 2: Motor parameter auto-tuning measuring the stopped motor 3: Online auto-tuning function	0	
P.302	Motor rated power	0~355	0	
P.303	Motor poles	0~8	4	
P.304	Motor rated voltage	0~440V	220/440V	
P.305	Motor rated frequency	0~400Hz	50Hz/60Hz (Note 2)	
P.306	Motor rated current	0~500A/5000A(Note 5)	Horsepower-based	
P.307	Motor rated rotation speed	0~65535 r/min	1410/1710 r/min (Note 2)	
P.308	Motor excitation current	0~500A/5000A(Note 5)	Horsepower-based	
P.309	Stator resistance	0~65535mΩ	Horsepower-based	
P.310	Rotor resistance	0~65535mΩ	Horsepower-based	
P.311	Leakage inductance	0~6553.5mH	Horsepower-based	
P.312	Mutual inductance	0~6553.5mH	Horsepower-based	
P.320	Speed control proportion coefficient 1	0~2000%	100%	
P.321	Speed control integral coefficient 1	0~20s	0.3s	
P.322	Switching frequency 1	0.00~P.325	5.00Hz	
P.323	Speed control proportion coefficient 2	0~2000%	100%	
P.324	Speed control integral coefficient 2	0~20s	0.3s	
P.325	Switching frequency 2	P.322~the maximum output frequency	5.00Hz	
P.350	Number of pulses per revolution of the encoder	0~20000	1024	
P.351	Encoder input mode setup	0~4	0	
P.352	PG signal abnormality (zero speed) detection time	0~100s	1s	
P.353	Motor over-speed detection frequency	0~30Hz	4Hz	
P.354	PG over-speed detection time	0~100s	1s	
P.994	Parameter copy readout	---	---	
P.995	Parameter copy write-in	---	---	
P.996	Alarm history clear	---	---	
P.997	(Reset)inverter reset	---	---	
P.998	Restoring all parameters to default values	---	---	
P.999	Restoring some parameters to default values	---	---	

Note: 1. The torque boost, motor rated current and stator resistance values are shown in the table as follows :

Inverter type	P.0	P.9
SF-020-5.5K	3	24
SF-020-7.5K/5.5K-G	3	33/24
SF-020-11K/7.5K-G	2/3	49/33
SF-020-15K/11K-G	2	65/49
SF-020-18.5K/15K-G	2	75/65
SF-020-22K/18.5K-G	2	90/75
SF-020-30K/22K-G	2	120/90
SF-020-37K/30K-G	2	145/120
SF-020-45K/37K-G	2	170/145
SF-020-55K/45K-G	2	212/170
SF-040-5.5K	3	13
SF-040-7.5K/5.5K-G	3	18/13
SF-040-11K/7.5K-G	2/3	24/18
SF-040-15K/11K-G	2	32/24
SF-040-18.5K/15K-G	2	38/32
SF-040-22K/18.5K-G	2	45/38
SF-040-30K/22K-G(S)	2	60/45
SF-040-37K/30K	2	73/60
SF-040-45K/37K-G	2	91/73
SF-040-55K/45K-G	2	110/91
SF-040-75K/55K-G	1/2	150/110
SF-040-90K/75K-G	1	180/150
SF-040-110K/90K-G	1	220/180
SF-040-132K/110K-G	1	260/220
SF-040-160K/132K-G	1	310/260
SF-040-185K/160K-G	1	340/310
SF-040-220K/185K-G	1	425/340
SF-040-250K/220K-G	1	480/425
SF-040-280K/250K-G	1	530/480
SF-040-315K/280K-G	1	620/530
SF-040-355K/315K-G	1	683/620

- The default value is determined by the set value of P.189. When P.189 = 0, the default value is 60Hz, which is applicable to 60Hz systems. When P.189 = 1, the default value is 50Hz, which is applicable to 50Hz systems.
- According to the value of P.186, please refer to the parameter instruction for P.22.
- Parameters P.190 and P.191 are the calibrating values. Therefore the default value for each machine may differ slightly.
- When the power is larger than 160KW, the precision of current displayed by P.9, P.56, P.306 and P.308 is 0.1A, and the current range is 5000A.

11) Parameter setting process

> The flow chart for switching the operation mode using DU01 operation panel:
When P.79=0:

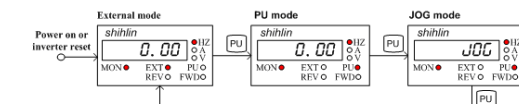

When P.79 = 1:

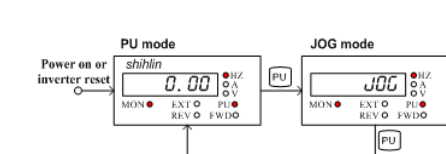

> The flow chart for switching the working mode using DU01 operation panel:

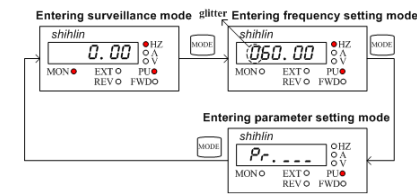

> Operation flow charts for monitoring mode with DU01:

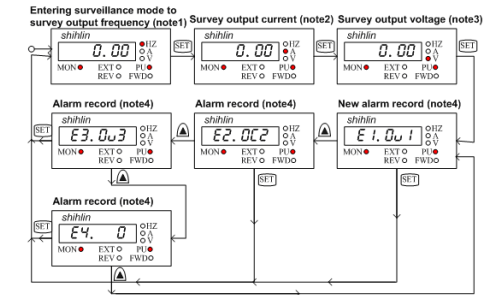

> Operation flow charts for frequency setting mode with DU01:

Use ▲ or ▼ key for setting up the frequency :

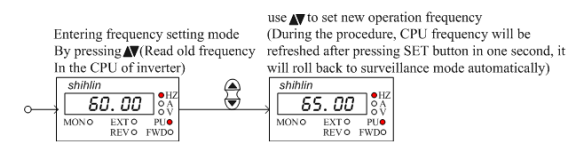

Press the MODE key to enter the frequency setting mode :

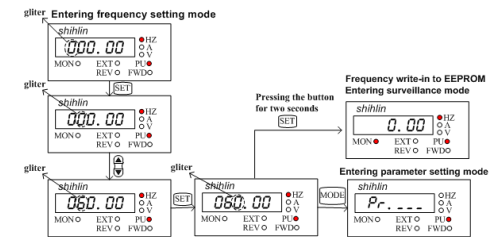

> Operation flow charts for parameter setting mode with DU01 :

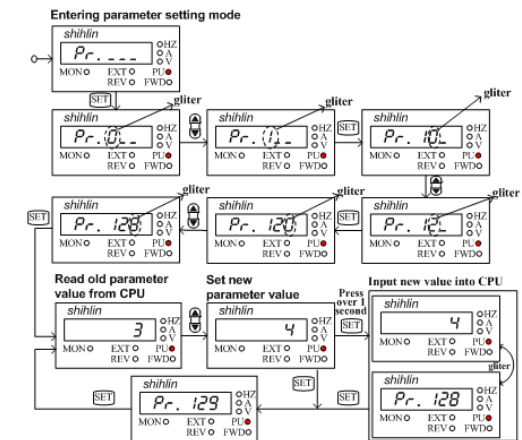

12) Others

> To improve our products, the parameters and contents may be modified, please contact the agent or refer to Shihlin websites (<http://automation.seec.com.tw/>) to download the latest version

